

# STEADICAM<sup>®</sup>

---

# ZEPHYR<sup>™</sup>

## Operating Manual



**STEADICAM®**  
**ZEPHYR™**



**STEADICAM® ZEPHYR™**

Operating Manual  
The Tiffen Company  
90 Oser Avenue  
Hauppauge, New York 11788  
631 273-2500  
800 645-2522  
631 273-2557 fax

[www.steadicam.com](http://www.steadicam.com)  
[steadicam@tiffen.com](mailto:steadicam@tiffen.com)  
[www.tiffen.com](http://www.tiffen.com)

Technical Support  
1-818-843-4600 ext.17

Manufactured in the United States of America

# Table of Contents

<b>Overview</b>	4	<b>Basic Operating</b>	22
<b>The Zephyr™ Sled</b>	6	<b>Advanced Techniques</b>	
Getting Started	8	Dynamic Balancing	24
Attaching the Camera	10	Low Mode	26
Balancing	12		
<b>The Vest</b>	14	Accessory for lightweight cameras	28
		Zephyr™ sled connectors and pin-outs	29
<b>The Arm</b>	16	Accessories	30
Setting Your Threads	17	Cases and Packing	31
Picking Up the Sled	18		
Adjusting the Lift	20		

Operating a Steadicam® stabilizer will take time and effort. One key to great operating is setting up and balancing your sled properly. Another is adjusting the vest to your body, and setting the arm to properly lift the load.

The next steps are learning how to balance yourself with the rig, how to stand and walk, how to prevent pendular effects as you move, and what each hand is used for.

This manual is to be used to instruct you in setting up and using your Steadicam® Zephyr™ stabilizer system. If you have not already done so, we strongly urge you to take a 2, 3, or 6-day Steadicam® workshop for the best possible training and start to your career as a Steadicam® operator (find more information about workshops at [www.steadicam.com](http://www.steadicam.com)).

The Zephyr™ is not a push-button magic stick that instantly creates great images. It's a precision instrument that responds to your touch. Although it's not that difficult to operate, it is a skill that takes a bit of time and effort to learn. The more effort and practice you put into operating, the better you will be, so it's important to develop good habits from the beginning.

Several two-hour sessions will get you started, but an operator can always be more skilled with a Steadicam® stabilizer and also be more effective and artistic in choosing how to start, move, and stop the camera. In the beginning, it's helpful and more fun to have a friend work with you. Take turns practicing and spotting for each other. Use a second video camera to record your exercises – how you stand and move is critical for great operating.

STEADICAM®, UltraBrite®, Ultra<sup>2</sup>® and Scout™ are trademarks of the Tiffen Company, LLC.

## Overview

The Tiffen Company takes great pride in producing the world's best stabilizers. The Zephyr™ stabilizer continues our tradition of excellence and innovation, filling the need for a high performance, lightweight, and low-cost rig.

Like all our models, the Zephyr™ stabilizer is designed to be user-friendly, field-serviceable, tool-free, straightforward, and versatile so the operator can quickly and easily configure the sled, arm, and vest to the best advantage for each shot. Change the sled length, balance, inertia, and go to low mode in a heartbeat. Solid, versatile, and fast – it's a breeze with the Zephyr™ system.



The base Zephyr™ system starts with a sturdy, two section, indexed telescoping carbon fiber post coupled to a sturdy two-axis vernier stage for quick and precise balancing. A new solid base is equipped with independently telescoping monitor and battery rods. The Zephyr™ system comes standard with the Tango™-ready, tool-free gimbal, 16:9 SD LCD Color monitor, and a single battery mount for 12 volts—either V-Lock or Anton Bauer (AB). 24 volts is optional.

A word about 12 and 24 volts as used in the manual: 12 and 24 volts typically refer to the nominal voltages required by cameras and accessories, but the voltage range accepted by the device might be 10 to 16 volts or 20 to 34 volts. Each camera or accessory has its own range of useful voltages.

Different battery chemistries and numbers of cells typically result in nominal battery voltages of 14.4 or 14.8 volts, or with two batteries in series, 28.8 or 29.6 volts. The actual voltage in a battery might be from 11 to 17 volts, depending on charge and battery type. Nominal battery voltages are always higher than the nominal required by the device, so that when the battery is almost depleted, it still has more voltage than that required by the device.

Options for the Zephyr™ stabilizer include a 7" high definition monitor, 24 volts, and a compact vest, plus batteries, chargers, cases, stands, power and video cables, low-mode kits, vehicle mounts, and other professional accessories. Visit [www.tiffen.com](http://www.tiffen.com) for more details.

The monitor and the batteries are adjustable in and out, which, along with the add-on Merlin™ weights, creates many choices for viewing, balance, and inertial control.

All of the above features are integral to the Zephyr™ stabilizer design, ready to be used when needed.



All “12 volt” monitor and power connector ports are supplied via unregulated battery voltage, typically 11 to 17 volts.

Included in the base package: the Zephyr™ Iso-Elastic Stabilizer Arm, Lightweight Zephyr™ Vest, Zephyr™ Docking and Balancing Bracket, 8 add-on Merlin™ weights, wheeled hard case with handle, 12 volt power cable, video cable, 2 video adaptors, the EFP instructional DVD, and the owner’s manual.

# The Zephyr™ sled

## The Zephyr™ Sled



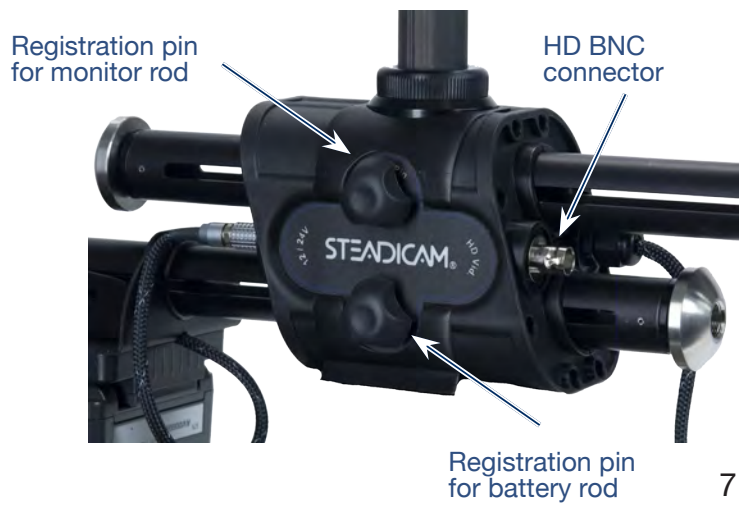
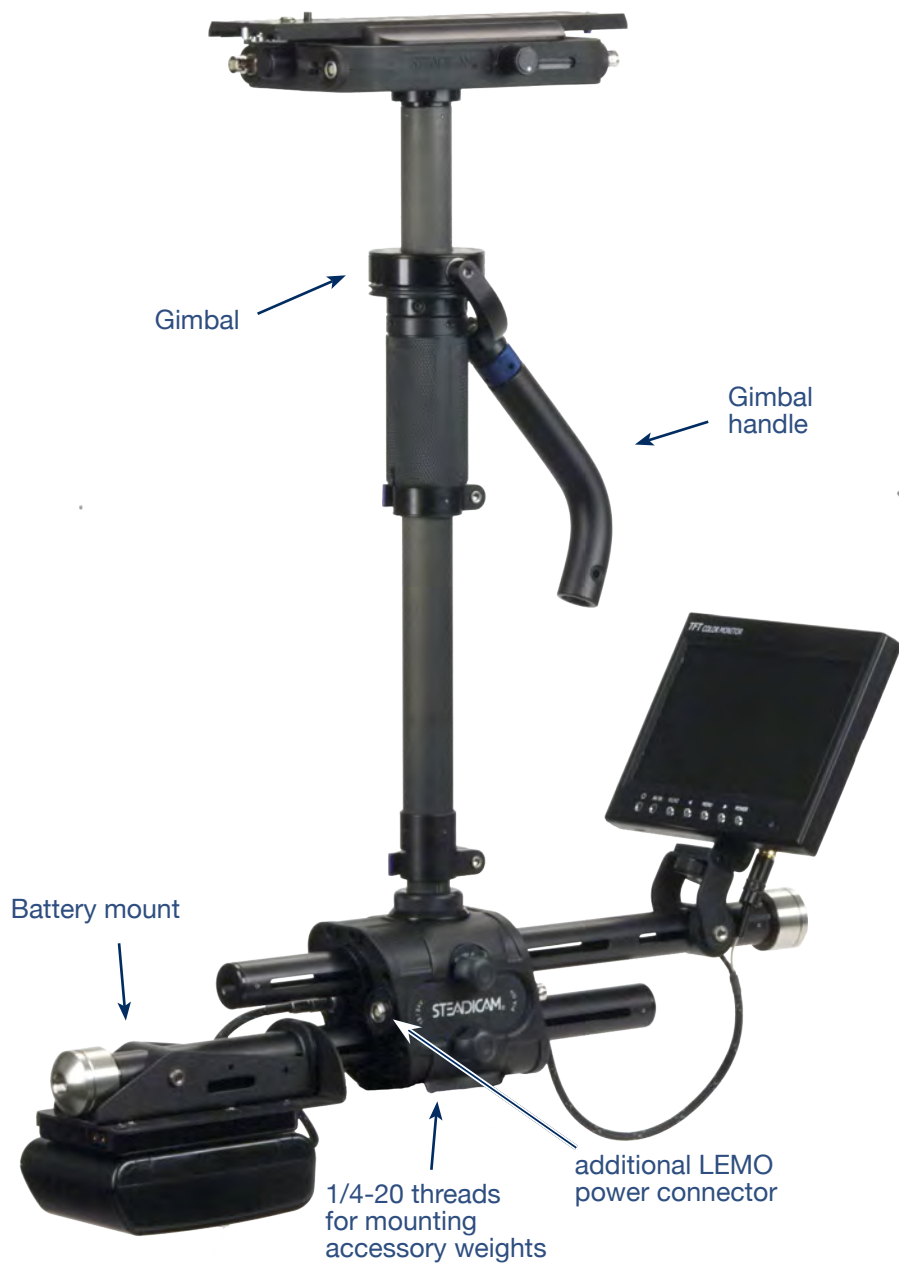

## *Prepare the stand and docking bracket*

### *Set up the stand and docking bracket:*

- Set up your stand at about chest height.
- Use one or more sandbags to stabilize the stand.
- Put the docking bracket on the stand and tighten the docking bracket locking knob.
- Push the button at the end of the aircraft pin and pull the aircraft pin out of the yoke.



## *Prepare the sled for the camera*

### *Adjust the monitor position:*

- Position the monitor and battery sliding rods as shown. If required, you may need to temporarily remove the locating pin for the monitor rod to achieve this extension.
- Add the accessory weights to the rods as shown. For starters, use 1 middle and 1 starter weight on each tube.
- Tilt the monitor to about 45 degrees.



### *Adjust the gimbal position:*

- Slide the gimbal close to the top of the center post, but always leave enough space between the gimbal and the stage to accommodate the docking yoke (about 1in/25mm).





***Adjust the battery position and attach the batteries:***

- Attach the battery onto the battery mount. Be sure the safety catch is engaged.



V-lock battery



AB battery

***Dock the sled in the docking bracket:***

- Hold the sled upright, with the monitor (front) to the left. Place the center post into the bracket so the bottom of the stage rests on the yoke.
- Push the aircraft pin back through the yoke, securing the post in the bracket.

***Remove the dovetail from the stage and set aside:***

- Loosen the dovetail locking knob until the dovetail can be tilted out sideways.
- Safety stops on the dovetail keep the dovetail from sliding off the stage when the dovetail locking knob is loose.
- The stops also prevent the dovetail from being inserted into the front or rear of the stage. Therefore, do not attempt to slide the dovetail into place from the front or back.



side to side adjustment knob

fore-aft adjustment knob



dovetail lock



**Back of stage:**

- Camera power connector. 3 pin LEMO: EGG.0B.303.
- Standard definition (PAL/NTSC) composite video in. BNC



**Front of stage:**

- HD BNC
- Two expansion ports for future options and accessories.
- Additional power connector. 3-pin LEMO: EGG.0B.303.



## Attaching the Camera

### *Attaching the camera to the sled*

We attach the camera to the sled via a dovetail plate. With the Zephyr™ stabilizer, this plate has safety stops on the ends, and several holes for mounting screws. We want to attach the dovetail to the camera so that we have the widest possible range of adjustment, both fore-aft and side to side.

We start this process by finding the camera's center of gravity (c.g.) or balance point, then properly position the dovetail plate relative to the camera's c.g.

#### *Finding the camera's c.g.:*

- If you like, remove the battery from your camera if it has an auxiliary power input, either 12 or 24 volts. With a very heavy camera (15+ pounds/6.8kg or so), this is a good idea, but it's not necessary or advisable with a very light camera.
- Attach all accessories, matte boxes, obie lights, etc. and load the tape or film. If the camera has a quick-release plate (tripod adaptor), leave it on the camera.
- Balance the camera fore-aft on a rod or pencil (as shown) and mark the balance point with a piece of tape.
- Repeat for side to side.

#### *Attaching the dovetail plate:*

- Examine the dovetail. Turn it over to locate the three rows of large and small slots, and the stops.
- Remove the screws that are stored at the front of the dovetail.
- Place the dovetail against the bottom of the camera (or quick release plate) and move the dovetail fore-aft until the second slot from the rear is over the camera's c.g.  
***This position is not intuitive, so pay close attention to this detail.***
- Now move the dovetail as little as possible until one or more screw holes are accessible. Choose holes as far apart as possible for maximum stability.
- Insert the screws and tighten with a screwdriver.



Finding the camera's fore-aft center of gravity.



Finding the camera's side to side center of gravity.



### *Mounting the camera on the sled:*

- Place the camera above the camera mounting platform. Be sure the locking knob is loose. Angle the right edge of the dovetail into the holder. Be sure to keep everything parallel. Lower the left side into the holder.
- If the camera won't drop fully into place, be sure the right side of the dovetail is fully inserted, all is parallel, and the locking mechanism is out of the way. It's a close fit.



- After the dovetail drops into place, slide the camera until the fore-aft c.g. mark is about .5in (12mm) behind the centerline of the telescoping posts. The post is 1.1in (28mm) in diameter, so you can use the back of the post as a guide for placing the camera c.g.



- Tighten the locking knob to fully lock the camera into place. You are now ready to static balance the sled.



- Camera power connector. 3 pin LEMO: EGG.0B.303.
- Standard definition (PAL/NTSC) composite video in. BNC

### *Connect the power and video cables and test that everything works:*

- Connect the BNC to BNC video cable (use the BNC to RCA adapter if necessary) from the camera to the video input on the back of the stage. If necessary, choose the camera's video output that allows you to watch playback as well as "live" video.
- If necessary, connect the power cable by plugging the three-pin Lemo into the Power output on the back of the stage and the other end into the appropriate DC power input on your camera. Several power cables are available for various cameras and voltages. See the accessories page for the power cable details.
- Secure the cables with cable ties, Velcro®, or gaffer tape. Leave enough slack for adjustment of the stage.
- Power up the monitor and camera to make sure you have a picture. If you do not, try adjusting the brightness and contrast controls; check the cables, battery voltage, etc.
- Turn off the camera and monitor.

*Now proceed to static balance the sled.*

## Balancing the sled

The Steadicam® Zephyr™ stabilizing system works, in part, by the careful balancing of components (camera, monitor, accessories, and battery). We always balance the sled to help us get the shot, so that the operator does the least amount of work to aim the camera. There are several components of balance. The first one to work on is “static” balance, where we balance the sled in all three axes (top-to-bottom, side to side, and fore-aft), so that the sled hangs upright and is not too bottom heavy.

*To adjust the balance, we need to put the sled on the docking bracket balancing stud where it can hang freely from the gimbal*

- Pull the aircraft pin and remove the sled and camera from the docking bracket.
- Release the top clamp knob and slide and extend the docking bracket. Tighten the locking knob.
- Place the gimbal’s mounting hole on the balancing stud.

If the sled is neutrally balanced (neither top nor bottom heavy) it’s impossible to balance the sled fore-aft or side to side, and the operator must do all the aiming of the sled – not good either.



### Top to bottom balance

Let’s start with top-to-bottom balance, as it is one of the least understood aspects of balance.

It’s best if the sled is slightly bottom heavy. Clearly, if it is top heavy, it will tip over. If it is too bottom heavy, it will hang upright (a good thing) but be hard to tilt and very hard to control as you move around (not good at all!).

So immediately, you should understand that top-to-bottom balance is a compromise between competing desires. If it is just slightly bottom heavy, it can be balanced to hang at a particular angle **and** easier to control.

How do we get the right top-to-bottom balance?

Note: changing the length also changes the range of lens heights. This can be a useful tool with any weight camera.

Note: Before letting go of the sled, be certain that it will hang more or less upright. If the sled wants to hang upside down, the camera weight is beyond the weight specifications of the Steadicam® Zephyr™.



When balancing a heavier camera, you may have to extend the post. While holding the bottom of the sled, release the post clamp and lengthen the post. Close the clamp.

First we position the gimbal, which acts as a pivot point, just a bit above the center of gravity on the center post, and here's how we do that:

- Rotate the center post to horizontal. Hold it securely.



- With one hand firmly holding the camera or the center post, open the gimbal clamp. **Remember to always keep the post horizontal when the gimbal clamp is loosened!**
- Grasp the center post and carefully slide the post in the gimbal. Use your thumb to push against the gimbal. Find the place where the sled is balanced on the gimbal like a seesaw on a fulcrum. Then slide the post through the gimbal about 1/2" (12mm) towards the battery. This will place the sled's c.g. 1/2" (12mm) below the gimbal yoke bearings, and the sled will be slightly bottom heavy.
- Close the gimbal clamp.

**WARNING: If you open the gimbal clamp when the center post is vertical, the whole sled will drop rapidly and damage your sled.**

We will fine-tune top to bottom balance after we get close to fore-aft and side to side balance. We may need to fine-tune the balance in one axis after we balance in another axis. The object is to get as close as possible to the best balance for the shot.

*Look at the sled from the side. If the sled is tipped up or down:*

- Hold the center post vertical.
- Move the camera forward or backward by turning the fore-aft knob until the camera is level. You can use a bubble level to help you find vertical.



*Fine tune the side to side balance:*

- Look at the sled from the front or rear. Adjust the side to side knob on the stage until the center post is vertical. Again, you can use a bubble level to help you find vertical.

*Now we are ready to fine-tune the top-to-bottom balance by using the "drop time" test*

- Make sure the dovetail locking knob is tight.
- It's good to have an assistant hold the stand.
- Rotate the sled to horizontal.
- Let go of the center post.
- Count how many seconds it takes the center post to fall through vertical.

If the rig has a drop time of less than two seconds it is too bottom heavy. You need to move the sled's c.g. upwards, closer to the gimbal. If the drop time is more than three seconds, move the sled's c.g. lower, further from the gimbal:

- With the rig horizontal, open the clamp and slide the centerpost through the gimbal about 1/8" (3mm) in the proper direction.
- Close the gimbal clamp.
- Re-do the drop test. Keep making small adjustments until the sled has a 2 to 3 second drop time.
- Recheck the fore-aft and side to side balance by looking at the sled. Trim with the fore-aft and side to side knobs as necessary.

Note: A drop time of 1 to 4 seconds might be best for a particular shot. You will eventually determine what works best for you for average shooting, and what works best for you for each shot. But let's start with a 2 to 3 second drop time.

# The vest

## The Vest

Use an allen key to unlock and adjust the angle of the shoulder connector.



Note: Shorten or extend the shoulder straps so that the clip is high on your shoulders when the chest straps are horizontal. Also be sure that the shoulder straps are evenly extended and at the same angle to the Velcro®.



Adjustable velcro® straps



# Putting on the vest

Please read the vest instructions completely before you try to put the vest on. It is very helpful to have a friend help you the first time you put on the vest. Otherwise use a full-length mirror.

## Open the vest

- Loosen both chest straps.
- Release the hip straps on the left side.
- Open the chest buckle on the left side.
- Open the shoulder buckle on the left side.



- Slip the vest on.
- Close the shoulder buckle.



- Close the chest buckle.
- Center the chest plate on your chest.
- Tighten the chest straps evenly and secure the loose, Velcro® ends.
- Push down on the chest plate to seat the shoulder pads on your shoulders.

- Pull out the chest plate release pin and adjust the center spar up or down so the hip pad sits centered on your hips. Replace the chest plate release pin in the nearest hole.



- Be sure the Velcro® straps are horizontal on the hip pads, and tighten the hip straps completely and evenly.



- Close the buckles at the chest and hips.
- The vest should be very snug, but not uncomfortable. Adjust the straps as necessary.

## Removing the vest

The vest should be unbuckled on the left side only, from bottom to top:

- Undo the hip strap first.
- Undo the chest buckle.
- Undo the shoulder buckle and slip out of the vest. When you put it back on, you will not need to readjust the chest plate or the chest straps.



Pay close attention to the good fit of the vest in the photo above. It's very important how the shoulder pads contact the shoulders and the shoulder connectors are not too high (a common mistake).

**Note:** A few operators have body shapes or sizes that are out of the general range of adjustments. You may find you have to add or remove padding, shorten or extend straps, etc. to make the vest fit perfectly.

## The arm

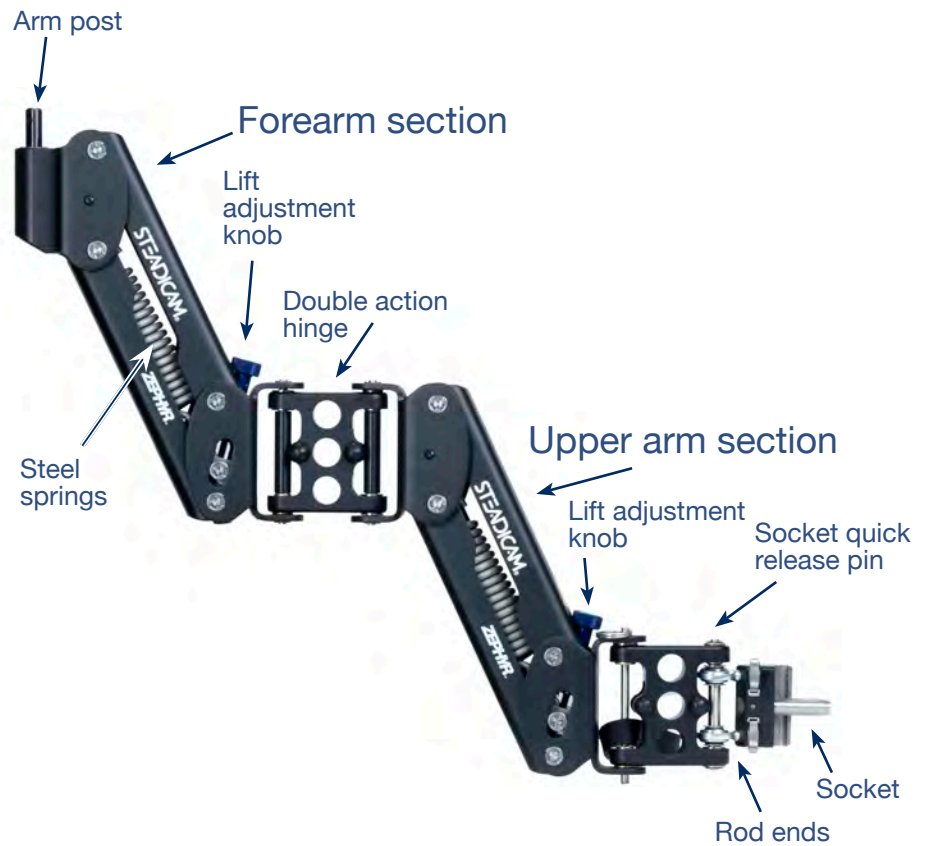

## Mounting the arm to the vest

The arm mates with the vest via an adjustable socket in the arm and a female socket block on the vest. The two adjustment screws in the socket block on the vest and two “rod ends” in the mating section of the arm determine the lift angle of the arm. These two adjustments are your “threads,” and they are specific to your body size and shape. Setting your threads correctly is critical for good operating.

Some combination of adjustment of these screws – and your physique and posture – will make the arm lift straight up when carrying the sled. The angles of adjustment are not directly “in-out” and “side to side”, but rotated about 30° clockwise (relative to the operator). We will suggest approximate threads to start, but the only real way to test your threads is to pick up the sled and see what happens. You can’t set your threads fully without picking up the rig.



The arm socket is inserted into the socket block on the vest.



## Determining your threads is part of basic operating technique

For almost all operators, regardless of body type, the typical adjustment for the “side to side” screws (the rod ends in the arm) is 1.5 to 2 turns out on the top screw and ALWAYS all the way in on the bottom screw.

Use the rollers when the arm is not under load. If you are flying the sled, lift it up with your left hand to take the weight off the screws before adjusting them. The two side to side screws work independently of one another. Do not tighten the lower screw, but be sure it is all the way in, and then back it out 1/8th of a turn.

The “in-out” screws work in tandem, and the adjustment varies greatly by the operator’s body type.

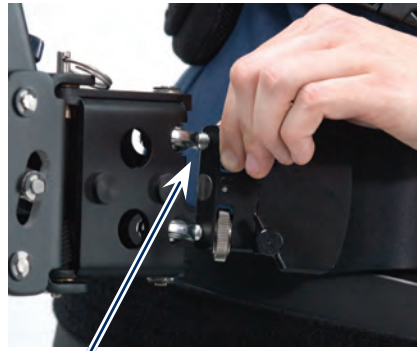

side to side: 2 turns out on top  
in-and-out: count threads here



## Adjusting your threads

- If you have big pectorals and a flat stomach, the top screw is almost all the way in. If you’ve been eating well and exercising less, the top screw will be further out.
- Always dial in the top screw first to your setting, then turn in the bottom screw until it just snugs up against the fitting. There is no need to tighten the bottom screw very hard.
- Always keep a hand on the free end of the arm, otherwise it might swing around and hit something, someone, or you in the face.
- With both pairs of screws properly adjusted, the sled will float in all positions with the operator standing in good posture with a vertical torso. If the threads are not adjusted well, the sled will tend to fly or fall away from you.

## Goofy foot

If you want to operate “goofy-foot,” – with the sled on the right side – you will need to reverse the socket block before starting.



- On the vest, remove the breast plate: Loosening the lock; pull the locator pin; and slide the plate completely off. Then remove the socket block in the same manner. Flip the block 180° and re-attach (above).
- On the arm, pull the aircraft pin to separate the socket from the arm. Turn it over and re-attach.
- Set the top screw about two turns out, and the bottom screw all the way in.

## Picking Up the Sled

### *Picking up the sled*



### *Undocking, setting your threads, and docking the sled*

*With the vest on and the arm attached to the vest, undock the rig:*

- Face the sled and bow at the waist. Do not bend your knees. It is helpful to have a friend spotting you the first time you do it.
- Align the gimbal mounting hole to the arm post and slip the arm post completely into the hole. It's easiest to align the parts if the gimbal handle is positioned behind the rig (i.e., not to the side, aimed at you).
- Use your right hand to hold the arm and gimbal together (frame 4).
- Place your left hand on the center post just below the gimbal to control the sled. Do not touch the camera (frame 4).
- Step forward and stand up straight. You are now flying the sled, but still locked in the dock.
- Pull the aircraft pin out of the docking yoke (frame 6).
- Step back from the stand to remove the sled from the docking bracket.
- Take a deep breath. Relax.
- Move the sled to a position about 45° off your left hip as shown.
- Aim the sled slightly across your body (frame 9).





Holding the rig might feel awkward at first. Don't worry – you will gain control and endurance rapidly as you practice. The first time is typically the most annoying, because there are so many adjustments to make before it all falls into place and “magically” works with you. It may be that you will want to adjust the lift capacity of the arm (see pages 20-21) before fine-tuning your threads. Eventually you must adjust them both.

### *Practice replacing the sled in the docking bracket*

- Step up next to the docking stand with the camera aimed to the left.
- Insert the center post in the bracket and rest the stage on the docking yoke.
- Insert the aircraft pin back in the docking yoke to secure the sled.
- Bow from the waist and step back.
- Move your left hand to the gimbal handle, and your right hand to the arm.
- Hold up the gimbal handle and let the arm post slide out of the gimbal mounting hole. Don't force it or bend your knees; just find the correct angle so that the arm post slips out of the gimbal.
- Always keep a hand on the free end of the arm, otherwise it might swing around and hit something.
- Rest. Stretch.
- When you don't have time to dock and undock, you can relieve some muscle tension by holding the rig close to your body on either side or clasping the camera close to your chest.

### *Test your threads*

- Stand as upright as possible, in good posture, with the rig off your left hip. Don't be stiff or tense. Do not ever let go of the sled completely, but let it move a little.
- If it tends to stay in place, try moving it further out in front of you. Lean back a little as you feel the vest pushing against your stomach and pulling your torso forward. The trick is to lean a little bit away from the rig – more if it's further from you, less as it's closer to you – so that the sled wants to stay in place or float next to you.
- If the sled wants to move off in one direction rather dramatically and you can't lean forward or back easily to correct it, you need to adjust your threads. Typically it's a matter of the “in-out” screws rather than the side to side screws.
- If the sled wants to move away from you, loosen the bottom in-out screw and dial in the upper screw a few turns. Snug up the lower screw and re-test.
- If the sled wants to move towards you, loosen the upper in-out screw a few turns, snug up the lower screw, and re-test.
- Do not get too fussy with your threads at this point, as much of the trick is learning to properly stand and move, rather than adjusting your threads.
- Take a few steps and experiment with the feel of it all. Try panning and tilting. Before you get tired, dock the sled.

## Adjusting the Lift

Important: The lift adjustment knobs can only be turned when the arm segments are slightly above horizontal. They cannot be turned when the arm is unloaded, i.e., when not lifting the sled, nor if the arm sections are boomed too far up or down. Do not force the lift knobs. At the right angle, they turn very easily.

## Setting the lift capacity of the arm

Now it's time to adjust the arm for the weight of your camera.

### Adjusting the arm

- With the vest on, attach the arm and undock the rig as before.
- Stand with the sled off your left hip, with the lens slightly crossing your body.
- Move the arm to the middle of its boom range and let it rise or fall. Do not completely let go of the sled.



- Turn the weight adjustment knob clockwise until the forearm wants to float slightly above horizontal.
- Keep making small adjustments until the forearm settles at a 5° angle up from horizontal.



- Repeat the process with the upper arm section, but this time try to get the upper arm to follow the forearm as you boom up and down.

- Ideally, each section of the arm should come to rest slightly above horizontal, about 5° to 10°.
- Adjust the arm section nearest the sled first (the forearm section).
- If the arm floats at too high an angle, pull the sled down with your left hand until the forearm section is about 5° above horizontal. Turn the weight adjustment knob counterclockwise until the forearm wants to float at this angle.
- If the arm floats at too low an angle, pull the sled up with your left hand until the forearm section is about 5° above horizontal.



- Remember, the weight adjustment knob turns freely when the arm section is slightly above horizontal. Never force it or use a tool to adjust the arm lift.

### *Now let's fly the rig again*

- Move the sled off your left hip as before. Keep the camera close. This is what we call the "Missionary."
- Move your torso ever so slightly to test how your body angle controls the sled.
- Repeat with the sled further away from you, but keep your torso vertical.
- The sled should stay in place with only a little help from your right hand.

CAUTION: IF YOU REST YOUR RIGHT HAND ON THE CONNECTING ARM, KEEP YOUR FINGERS OUT OF THE SPACE BETWEEN THE ELBOW AND THE ARTICULATING ARM. A SUDDEN RISE OF THE CAMERA COULD INJURE YOUR FINGERS IF THEY ARE IN THIS SPACE.



Boom the sled all the way up and down while watching the arm sections. Be sure you are in good form at all times. The upper arm should follow the forearm smoothly and not lag behind in either direction.

Do not bend over or lean back as you boom the sled up and down. Boom the sled with your right hand; your left hand is just for aiming the sled and camera.



## Hand grips

The two-handed technique was invented by Garrett Brown while working on *The Shining*, and it has been the preferred method of operating ever since.

Basically, the right hand does the work of positioning the sled in space (moving horizontally and vertically relative to the body), and the left hand aims the sled (and therefore the camera) by panning and tilting.

If the sled is properly balanced, very little force will be needed to aim the camera. Clenching the center post or gimbal hard will counteract the sled's "float." Light control is the key to a steady camera and smooth moves.



The left hand also has the interesting job of keeping the sled level as we move about. As we accelerate or decelerate, go around corners, etc., the left hand must prevent the sled from going off-level before it happens. One of the big operating skills is anticipating how the sled will behave as we move along. There are several classic "grips" we use to aim and control the sled.



The preferred grip, using the pinkie finger to prevent a pendulum effect.



## Finding your grip

- Grab the center post with your left hand just below the gimbal. All five fingers should be LIGHTLY in contact with the post, but this isn't a tea party. Don't just use your fingertips – wrap you fingers a bit around the post.
- The right hand fine tunes the position of the sled, moving it side to side or closer to or farther from your body, and booms the arm up and down. It also has the job of eliminating the bounce of the springs – i.e., preventing unwanted up and down movements as you move along.
- Grab the gimbal handle with your right hand.
- Make sure that this hand does not cross the bearing and touch any part of the Y-shaped yoke, as this will influence the aiming of the sled.



Also used, the full hand grip: all fingers surround the post with a light touch.



## *Basic movement*

Try moving around and get used to the way it feels. Pay attention to how your movements and posture affect the sled.

Relax your muscles and control the Zephyr™ stabilizer rig with your body position and a light, fingertip touch.

Leave the monitor turned off for now. Don't worry about making shots – you want to experiment, test, play.

Get used to walking with the sled next to you.

## *Balancing with your body*

As the sled gets farther away from your body, you must lean back a tiny bit more and use your arm reach to keep that light balanced touch.

If you lean forward, the Zephyr™ will try to move away from you — fast! — requiring a firmer grip, tiring your back muscles more quickly, and most importantly, not flying properly with that great Steadicam® stabilizer feel.

## *Placing the camera in space*

Swing the arm around to find its range of motion. Practice gentle boom moves with your right hand. Find the lowest and highest positions the camera can reach. Avoid hitting the stops as you boom (it won't hurt the arm, just your shot).

## *More Practice and Training*

For operators who have not yet taken a workshop, we (once again!) strongly urge you to do so, as it is the quickest way to learn how to operate properly.

However, there are several good training videos, including the 1990 Classic EFP Video Training Tape, which has been remastered to DVD. Although some of the information on the EFP video is specific to the EFP, most of the concepts, information, and exercises are still taught in the workshops today.

We suggest you spend some time with your Steadicam® stabilizer learning how to start and stop moves cleanly, pan and tilt, boom up and down, walk the line, do switches, track sideways, do pass-bys, use long lenses, and a host of other techniques.

You already know what you want to do with your Zephyr™ stabilizer. The exercises and concepts presented on the video will help you quickly develop the necessary skills to make your shots.

As often said in the workshops, running around chasing your dog is fun for awhile, but it's hard to judge how well you did or if you are improving.

Many experienced operators are still perfecting their moving camera skills after 25 years of operating, and most of them thought they were pretty good at the end of their first workshop. How good you get is part of the artistry and fun of being an operator. You have a great tool in your hands. Practice, practice, practice.



## Dynamic Balancing the Steadicam® Sled

A sled is in dynamic balance when the center post remains vertical as the sled is panned (and this is critical) at any and all panning speeds.

Dynamic balance is extremely important for precise operating and for whip pans.

For each arrangement of camera, monitor position, post length, accessories, etc., there are many possibilities for statically balancing the system.

However, for each arrangement of camera, monitor position, post length, accessories, etc., there is only one combination that balances the sled both

statically and dynamically. There is some leeway as to the required precision of dynamic balance. What is acceptable depends upon the operator and the situation.

Dynamic balance can very easily and quickly be achieved by the trial and error method.

In all cases, when a sled is in dynamic balance, both the camera's c.g. and the battery's c.g. will be to the rear of the centerline of the center post. This rule gives you some point to begin balancing the system.

### Three figures to study for understanding dynamic balance

The top figure looks like the Model One or the SK sled. The camera c.g. is centered over the post; the monitor and battery are on the same horizontal plane, and their common c.g. is in the post. This unit is in dynamic balance and pans flat.

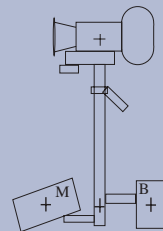

The second figure has the monitor raised a bit. This looks like most sled configurations, in either high or low mode. Note that the battery c.g. is closer to the post, and the camera c.g. has moved to the rear. Why?? See the third figure.

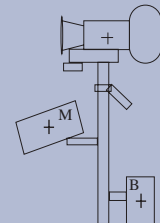

In the third figure, the monitor has been raised all the way up in front of the camera. It's absurd, of course, but it makes a point. Now the common monitor and camera c.g. is over the post, and the battery's c.g. is directly under the post.

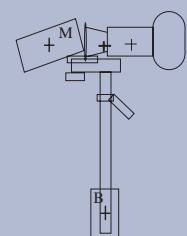

So you can see that as the monitor is raised, the camera c.g. must move to the rear and the battery c.g. must move towards the post. With most sleds, the monitor c.g. is raised above the battery c.g., therefore the camera c.g. is always to the rear of the centerpost.

It typically works out that the camera c.g. is pretty close to .5in (12mm) to the rear – a bit more if the camera is light or the monitor is higher, and somewhat less if the camera is very heavy or the monitor is lower.



We put the rig in dynamic balance by first choosing the monitor position and then placing the camera close to its final position. Then we discover the one-and-only ideal position for the battery by the trial and error method.

First, set up your sled at the proper length for the shot and place the monitor where you want it for proper viewing and inertial control. Typically with the Zephyr™ stabilizer system, the monitor rod will be extended slightly past the first stop and two weights are attached to the rod (see page 8). Two weights are also attached to the battery rod.

Next, position the camera so that its c.g. is about .5in (12mm) behind the center post. The center post is just over an inch in diameter, so you can use the back of the post as a guide. Next, static balance by sliding the battery in or out so that the sled hangs perfectly vertical fore and aft. Make sure the top-to-bottom balance is set with a drop time of 2 to 3 seconds.

Trim side to side with the camera, using the knobs on the stage. Fine-tune the fore-aft balance with the camera. You want the sled's post perfectly vertical. A spirit level will help you get the post vertical.

Give the sled several careful test spins. Very important: do not spin the rig very fast – certainly not much faster than a normal panning speed (3 – 6 rpm). Note the results. Is it good or bad, i.e., does it pan flat or wobble? Is it your technique or is the sled out of dynamic balance?

If your sled is not in dynamic balance, do not move the monitor!

Instead, move the battery a little bit first, then rebalance statically with the camera. There are only two directions to move the battery: out or in. You have a 50% chance of choosing the right direction, so stop worrying about it and give one direction a test. Just be sure to make a note of which direction you move the battery.

Each time you lock the battery in a new position, you must rebalance the sled statically with the camera. Do not move the monitor! Once you are in static balance, spin the sled again. Is it better or worse? Again, you have two choices for moving the battery.

Re-rack, rebalance, and spin again (and again!) until the sled pans flat. This should not take a lot of time.

When the battery is within about .25in (6mm) of ideal, the sled will behave nicely – pan flat – and feel “sweet.” We suggest you do not attempt to do this for the first time on set!

Adding any accessory or extra Merlin weights to the sled will affect both static and dynamic balance. Changing the length of the sled, and/or moving the monitor in or out will change both static and dynamic balance.

How much will dynamic balance change? It depends on how much things have changed.

In practice, it's a lot easier than it sounds on the page, and luckily, there's one great gift in all this: it doesn't matter for dynamic balance what weight camera you are using or if you change lenses, filters, etc. Really!

So if you make any changes with the camera – or use a different camera – there are no worries about getting back in dynamic balance! You only need to rebalance statically and you will be in dynamic balance again. Honest.

Put the other way around: you can set up your rig in various ways with a practice camera at home, making it long or short, monitor in or out, with an extra weight, etc. Just note or mark the positions of the monitor and batteries, and you will be able to get into dynamic balance quickly on set, regardless of the camera you carry. Really. Honest. No fooling.

For the complete story, see the Dynamic Balance Primer and play with the Dynamic Balance Spreadsheet, available online at [www.steadicam.com](http://www.steadicam.com).

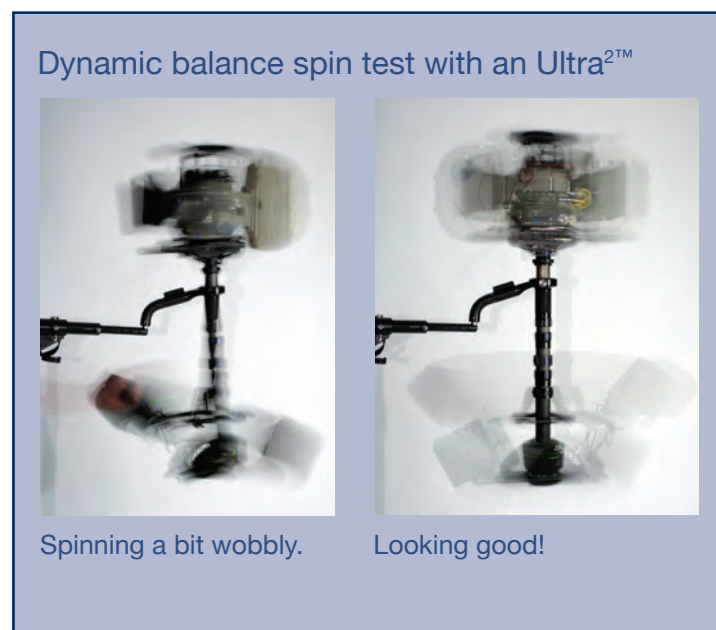

## Configuring the sled for low mode

In order to configure the sled for low mode operating, you must:

- Flip the monitor and the camera upside-down.
- Attach the F-bracket to the gimbal. Use the provided safety pin.
- Rebalance the sled, both statically and dynamically.
- You also might change to a longer post in the arm and/or raise the socket block on the vest to restore some of the arm's lost boom range.



The camera will need some means of attaching a second dovetail to the top of the camera.



A low mode handle clamp (P/N 802-7417) works for some cameras, but be sure the camera's handle is strong enough. Many plastic handles on video cameras are inadequate, and a custom cage or bracket is required.



Many film cameras come with dedicated low mode brackets and 100% video viewfinders. Some camera-specific low mode bracketry might also provide a means of mounting motor rods (or a dovetail with motor rods), and this system should not interfere with camera functions or working with the camera in high mode.



Most operators work with the low mode bracketry and second dovetail in place — ready to go at all times.

Attach the second dovetail directly above the first dovetail. Check that it does not interfere with changing tapes, film mags or any other camera functions.

Tip: Many video cameras – or video cameras with film lens adaptors – do not have a proper way to mount a dovetail above the camera. We suggest you use the “bottom” dovetail for low mode, shooting upside down. You will need to flip the image in post production, so be sure that’s okay before you shoot. You can either leave the monitor upside down, or physically flip it over for better viewing. The latter will require electronic flipping of the image.

Flip the monitor by unscrewing the monitor mount, turn the monitor over and replace the screw.

Attach the F-bracket to the gimbal handle by inserting the post into the gimbal handle and securing it with the pin. The F-bracket brings the arm back into a proper relationship with the inverted sled. Without an F-bracket, the end of the arm can be next to the camera. When this is the case, switches are impossible and operating is severely limited.



Balancing on the stand with the F-bracket attached.



Hand positions for operating with the F-bracket.

### *Balance the sled*

The sled can be balanced the same as in high mode. Hang the rig by its gimbal on the balancing stud. The camera will still be on top, but it is upside down. Balance statically and dynamically. Once balanced, adjust your drop time so the camera now falls to the bottom of the rig: simply slide the gimbal towards the electronics to achieve a proper drop time. Cautionary Tip: In low mode, the dovetail lock works better if the camera weight is supported as you lock the dovetail.

### *A useful trick*

The range of low mode lens heights can be lowered by extending the center post and/or making the rig more bottom heavy.

### *Low mode operating*

Traditionally, it’s considered harder to operate in low mode than in high mode. Why?

Several factors may work together to make low mode operating harder. The operator usually holds the sled further from his body than in high mode. The operator’s hands are not at the same height. Many times, the post is tilted from vertical. The boom range is sometimes reduced. The rig may not be in dynamic balance. The operator often cranes his neck to see the image. In addition, every director wants the lens height lower or higher than one can properly reach. And it’s just plain weird to have the monitor so far above the lens.

## *Accessory for lightweight cameras*

When using very lightweight cameras, it's often better to add weight to the camera or stage, so that the gimbal position remains close to the stage.

It's very easy to use the Merlin™ Stage Weight Bracket and any number of Merlin™ weights as shown.

See the accessory section for part numbers.

You also can make a custom weight cage for your lightweight camera - we use a variety of cages in the workshops. If you make a custom cage, be sure you can access the battery, media, and all other functions. Many operators add a quick release plate to their weight cage to facilitate easy changes.



# Zephyr™ sled connectors and pin-outs

**STAGE FRONT**

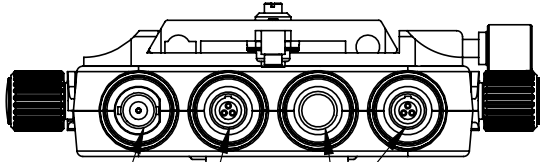

- HD VIDEO BNC
- 12/24V POWER 3-PIN LEMO EGG-0B-303 PIN-1 = GND PIN-2 = +12V PIN-3 = +24V
- TALLY IN/OUT 8-PIN HIROSE HR212-10R-8SD PIN-1 = GND PIN-2 = RESERVED PIN-3 = RESERVED PIN-4 = RESERVED PIN-5 = RESERVED PIN-6 = RESERVED PIN-7 = TALLY IN PIN-8 = TALLY OUT

**STAGE REAR**

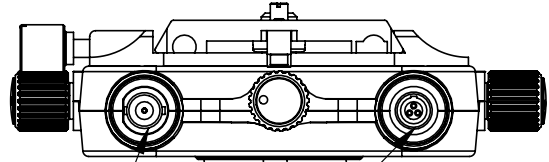

- COMPOSITE VIDEO IN BNC
- 12/24V POWER 3-PIN LEMO EGG-0B-303 PIN-1 = GND PIN-2 = +12V PIN-3 = +24V

**SLED BASE FRONT**

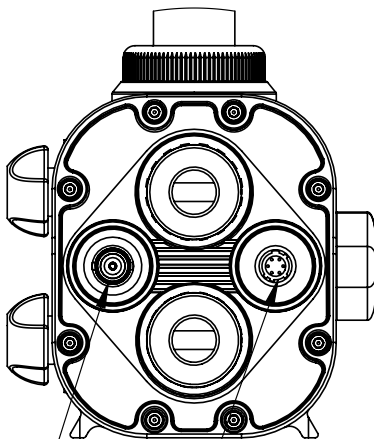

- HD VIDEO BNC
- MONITOR OUT 6-PIN HIROSE HR10-7R-6S
- PIN-1 = GND
- PIN-2 = VIDEO GND
- PIN-3 = COMPOSITE VIDEO
- PIN-4 = +12V
- PIN-5 = TALLY OUT
- PIN-6 = GND

**SLED BASE REAR**

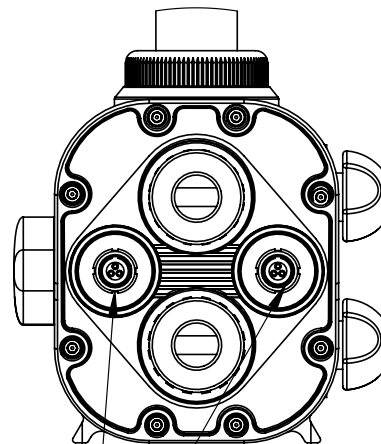

- 12/24V POWER 3-PIN LEMO EGG-0B-303 PIN-1 = GND PIN-2 = +12V PIN-3 = +24V

## Equipment and accessories

Zephyr™ sled	
Zephyr™ arm	
Zephyr™ vest	
Hard case	
Cable, 3 ft video	078-4122-01
Cable, 12V power	078-7351-01
7" 16:9 Monitor	807-7500
Docking bracket	803-7900
Adaptor, phono-BNC	JCK-130000
Adaptor, BNC-RCA	JCK-130001
Instruction manual	LIT-809000
DVD, EFP Training	DVD-200504



## Optional accessories

The Steadicam® Operator's Handbook	LIT-900000
Steadicam® Tango™	
Merlin™ stage weight bracket	801-7940
Dovetail plate assembly	802-7417
Low mode kit	078-7393-01
Video low mode cage	078-2038-01
F-bracket for low mode	300-7901
Merlin™ Start Weights	801-7920-04
Merlin™ Middle Weights	801-7920-05
Vehicle kit	078-7410-03
SteadyStand™	601-7910
Mounting block	803-7801
Thumb screws for block	078-0627-01
Long straps for vest	803-7817
Long arm post	602-7237-01
Cable, 12V power, spare	078-7351-01
Cable, 3 ft video	078-4122-01
1/4-20 camera screws	078-1121
3/8-16 camera screws	078-1122
Tool pouch	FFR-000013
Saddle bag-sand bag/portfolio	FFR-000014
Steadicam® cap	FFR-000021
Trolley for system soft case	DAA-22B



## Batteries

PowerCube™ battery	FFR-000035
IDX VL-4S battery charger	FFR-000008
IDX VL-2SPlus battery charger	FFR-000005
PowerCube™ battery hard case	011-0368
Anton Bauer Dionic HC (Li-Ion) battery	FFR-000151
Anton Bauer dual charger	FFR-900152
Anton Bauer quad charger w/ LCD display	FGS-900059

Visit [www.tiffen.com](http://www.tiffen.com) for a complete list of Steadicam® accessories.

## *Also recommended*

Wireless follow focus system and brackets  
Video transmitting and receiving system  
Wired zoom control system  
Camera specific low mode brackets  
Inertial augmentation  
(Antlers™ or Gyros)  
Video recording system

## *Cases & packing*

When repacking the sled into the case, make sure the gear gets wiped down and not put away wet. Remove the batteries. Don't leave any loose components in the case as they may work their way over to the monitor and scratch the display. The arm should be packed inside the vest to keep things compact.

Most operators have several other cases for their accessories, tools, low mode brackets, video recorders, video transmitters, diversity receivers, remote focus equipment, etc.



Zephyr™ stabilizer system shown with the optional low mode kit.

Disclaimer: There is no implied or expressed warranty regarding this material. Specifications, accessories, etc. are subject to change without notice.



The Tiffen Company, 90 Oser Avenue, Hauppauge, NY 11788  
• 631-273-2500 • 1-800-645-2522 • [www.tiffen.com](http://www.tiffen.com)  
Tiffen Steadicam® Operations, Glendale, CA • 818-843-4600  
• 1-800-593-3331 • [www.steadicam.com](http://www.steadicam.com)